

B-1308

L handle lock

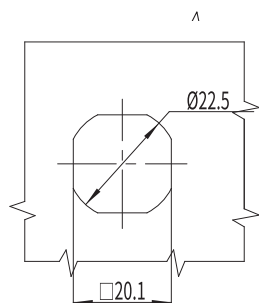
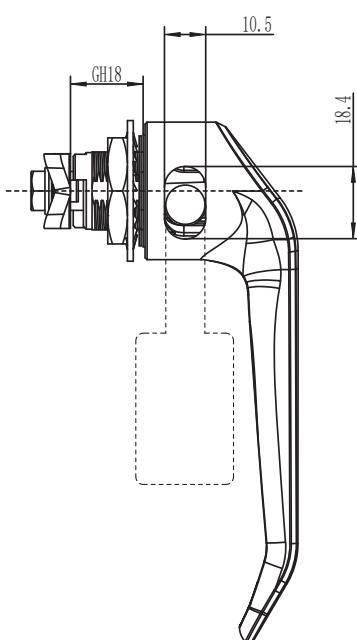
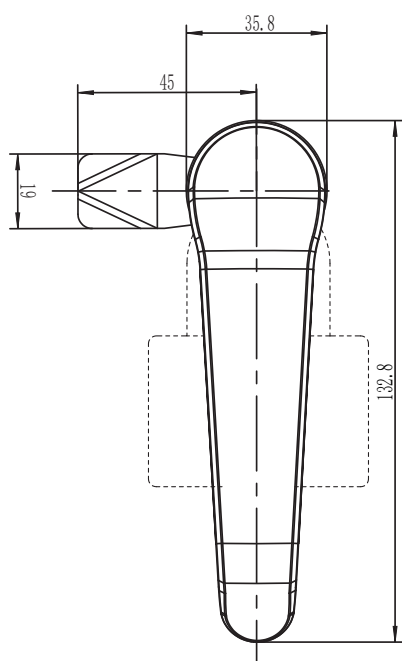

开孔尺寸
Panel Outout

IP65

RL

S
SUS304 SERIES



选型 Model selection

A1SUS304
30 电镀铬
30Electrochrome plating
40 粉末涂层黑
40Powder coated black

B-1308-LH-A1

L 代表钢柱长度
L represents the length of the steel bolt
H 代表有效高度
H represents effective height

1. Material and surface treatment:
Lock body, handler: Zamak DIN-EN 1774-ZnAl4Cu1 or SUS304
Steel bolt: iron galvanized or SUS304
Sealing ring: EPDM foam

2. Performance parameters:
Protection class: IP65

3. Remarks:
Stainless steel Padlockable on request

1. 材质及表面处理:
锁体, 手柄: 5#锌合金 SUS304
钢柱: 铁镀锌或 SUS304
密封圈: EPDM发泡胶。

2. 性能参数: 防护等级: IP65

3. 备注:
配不锈钢挂锁

如需获得产品 3D 模型图, 请联系 WWW.FORNDLOCK.COM