

L handle lock

B-1309



RL

IP65

S
SUS304 SERIES

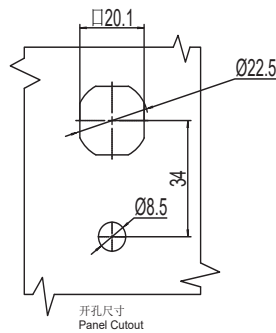
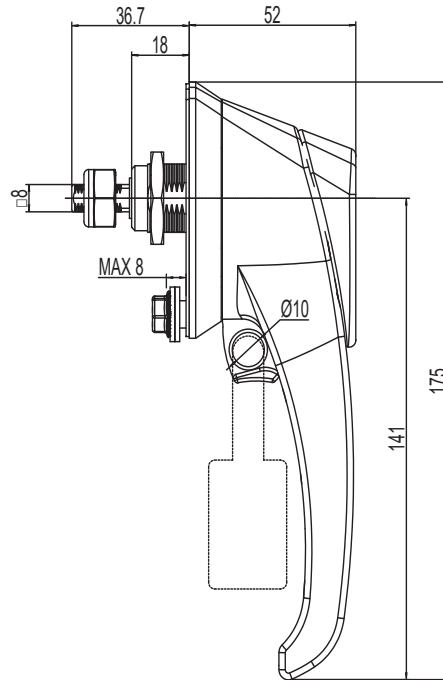
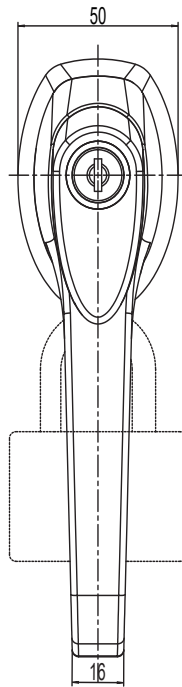

WWW.FORNDLOCK.COM

如需获得产品3D模型图，请联系

1. Material and surface treatment:
Lock body, handler : Zamak DIN-EN 1774-ZnAl4Cu1 , SUS304 or Electrochrome plating
Steel bolt: iron galvanized
Sealing ring: EPDM foam.

2. Performance parameters:
Protection class: IP65

3. Remarks:
Optional dedicated key
Default CH751 key

1. 材质及表面处理:
锁体, 手柄: 5#锌合金喷塑黑, SUS304或电镀铬
钢栓: 铁镀锌
密封圈: EPDM发泡胶

2. 性能参数: 防护等级: IP65

3. 备注:
专用钥匙可选
默认 CH751 钥匙

	锌合金 Zinc alloy		不锈钢 Stainless steel
	喷塑黑 Powder coating black	电镀铬 Electrochrome plating	
无钥匙锁芯 non-locking	B-1309-001-40	B-1309-001-30	B-1309-001-A1
CH751 钥匙锁定 CH751 key locking	B-1309-100-40	B-1309-100-30	B-1309-100-A1
双翅 5mm Double bit 5mm	B-1309-015-40	B-1309-015-30	B-1309-015-A1
三角 8mm Triangular	B-1309-038-40	B-1309-038-30	B-1309-038-A1
四方 7mm Square 7mm	B-1309-047-40	B-1309-047-30	B-1309-047-A1
内六角 8mm Hexagon female 8mm	B-1309-068-40	B-1309-068-30	B-1309-068-A1
2x4mm 直槽型 2x4 slot	B-1309-112-40	B-1309-112-30	B-1309-112-A1
外六角 6mm 型 Hexagon male 10mm	B-1309-160-40	B-1309-160-30	B-1309-160-A1
内六角 8mm 带销 3mm Hexagon female 8mm with 3mm pin	B-1309-268-40	B-1309-268-30	B-1309-268-A1