

## Rotary latch

## I-3000



### 垂直

(图示为左侧驱动装置)

### Vertical

(The picture shows the drive on the left)

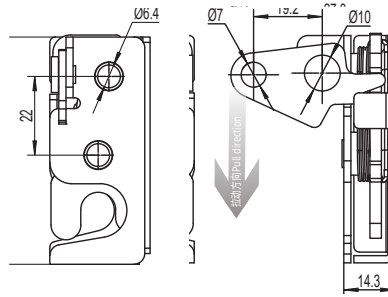

### 加长垂直

(图示为右侧驱动装置)

### Lengthen vertical

(The picture shows the drive on the right)

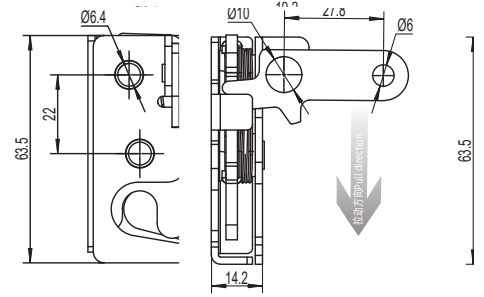

### 顶部

(图示为左侧驱动装置)

### Top

(The picture shows the drive on the right)

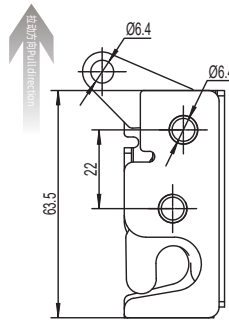

### 顶部

(图示为右侧驱动装置)

### Top

(The picture shows the drive on the right)

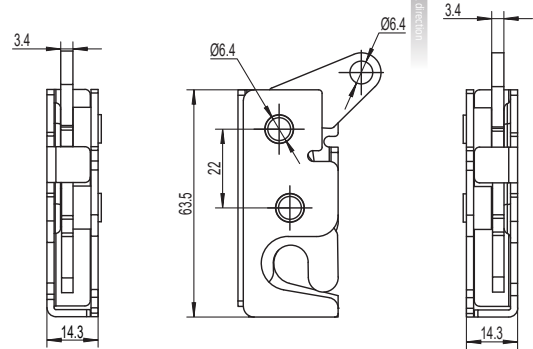

WWW.FORNDLOCK.COM

如需获得产品3D模型图，请联系

## 选型 Model selection

1. 单级，左侧 Single stage, Left side
2. 单级，右侧 Single stage, Right side
3. 双极，左侧 Double stage, Left side
4. 双极，右侧 Double stage, Right side

1. 垂直驱动 Vertical drive
2. 加长垂直驱动 Extended vertical drive
3. 顶部驱动 Top drive

## 3000-SI-B0-10

1. Ø6.4 通孔 Through-hole
2. M6x1 螺纹 Screw thread

10. 碳钢镀锌 Galvanized iron  
A1.SUS304

1. Material and surface treatment:  
Main body: Steel, galvanized or zinc nickel  
or SUS304

1. 材质及表面处理:  
主体: 钢, 镀锌或锌镍, 或 SUS304