

I-3004

Rotary latch

垂直
(图示为左侧驱动装置)
Vertical
(The picture shows the drive on the left)

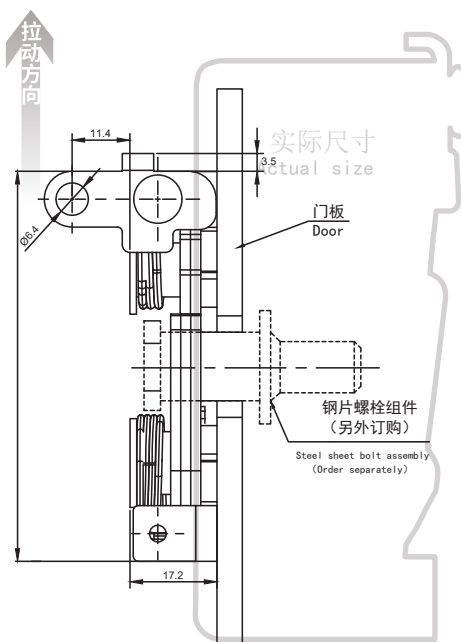
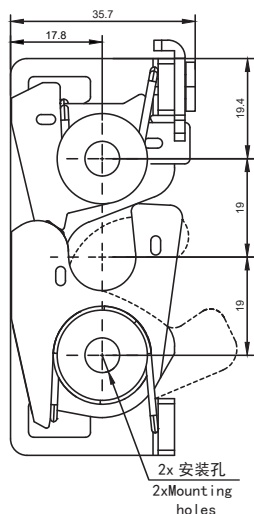

两点式驱动装置
(图示为左侧驱动装置)
Two-point drive
(The picture shows the drive on the left)

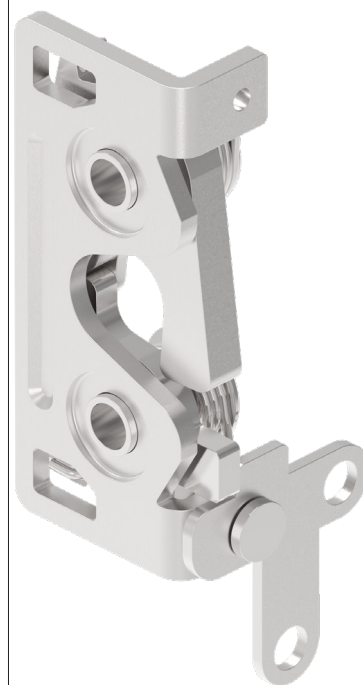
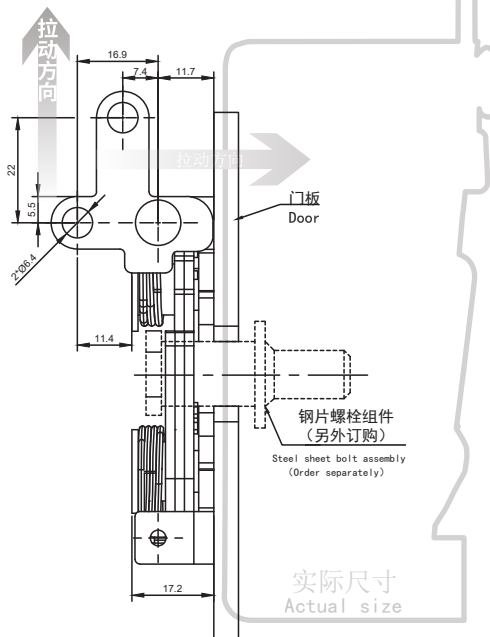
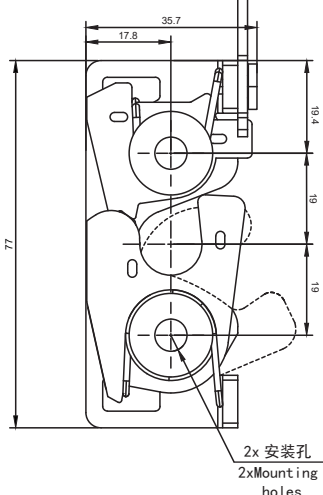

如需获得产品 3D 模型图，请联系 WWW.FORNDLOCK.COM

选型 Model selection

- | | |
|------------------------------------|---|
| 1. 单级, 左侧 Single stage, Left side | 1. 垂直 Vertical drive |
| 2. 单级, 右侧 Single stage, Right side | 2. 两点式 Two-point drive |
| 3. 双级, 左侧 Double stage, Left side | 3. 底部驱动 Bottom drive |
| 4. 双级, 右侧 Double stage, Right side | 4. 双拉杆 - 底部及垂直 Double tie rod - bottom and vertical |

3004-SI-BL-10

10. 碳钢镀锌 Galvanized iron
A1.SUS304

1. $\Phi 6.7$ 通孔 Through-hole
2. 1/4-20 螺纹 Screw thread
3. M6x1 螺纹 Screw thread

1. 标准 Standard
2. 带减震器型号 With shock absorbers

1. Material and surface treatment:
Main body: Carbon steel galvanized or SUS304

1. 材质及表面处理:
主体: 碳钢镀锌或 SUS304