

Rotary latch

I-3005



单级—垂直 (图示为左侧驱动装置)
Single Stage - Perpendicular
(left hand actuation shown)

带减震器的型号
Integrated Bumper Version
(dimensions same as standard version except as shown)

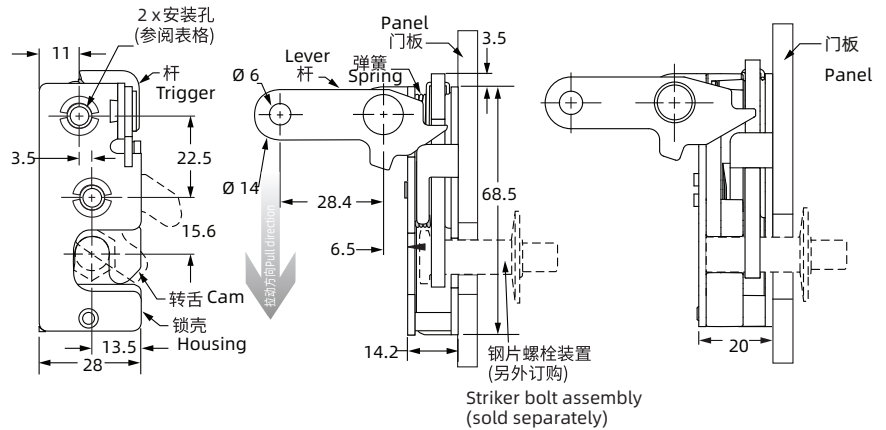

单级—直列式 (图示为左侧驱动装置)
Single Stage - In-Line
(left hand actuation shown)

带减震器的型号
Integrated Bumper Version
(dimensions same as standard version except as shown)

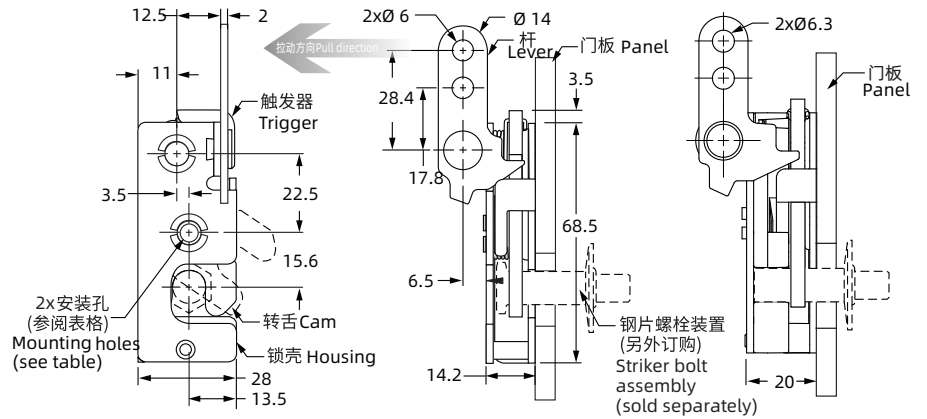

选型 Model selection

1. 单级, 左侧 Single stage, Left side
2. 单级, 右侧 Single stage, Right side
3. 双极, 左侧 Double stage, Left side
4. 双极, 右侧 Double stage, Right side
1. 把手型驱动 Handle drive
2. 底部驱动 Bottom drive
3. 顶部驱动 Top drive
4. 垂直驱动 Vertical drive
5. 直列驱动 In-line drive
6. 两点驱动 Two-point drive
7. 直接驱动 Direct drive
8. 双触发, 垂直 / 底部驱动 Dual trigger, vertical / bottom drive
9. 双触发, 垂直 / 顶部 Dual trigger, vertical / top drive

3005-SI-BL-10

10. 碳钢镀锌 Galvanized iron
A1.SUS304

1. $\Phi 7.2$ 通孔 Through-hole
2. 1/4-20 螺纹 Screw thread
3. M6x1 螺纹 Screw thread

1. 标准 Standard
2. 带减震器型号 With shock absorber

WWW.FORNDLOCK.COM 请 联系 如 需 获 得 产 品 3 D 模 型 图

1. Material and surface treatment:
Main body: Carbon steel galvanized or SUS304

1. 材质及表面处理:
主体: 碳钢镀锌或 SUS304